

# SMT Gate Drive Transformer



8.20 x 6.60 x 5.40mm

AITC-449



RoHS/RoHS II compliant

## FEATURES:

- Wide operating frequency from 50kHz to 2MHz
- Standard EP5 SMT package
- A wide operating temperature range from -40°C to +125°C
- Space saving 8.2 x 6.6 x 5.4mm, RoHS compliant SMD package

## APPLICATIONS:

- DC/AC Converter
- AC/AC Converter
- DC/DC Converter
- Motor Controller

## STANDARD SPECIFICATIONS:

Parameters	Minimum	Typical	Maximum	Units	Notes
Operating Temperature	-40		125	°C	
Storage Temperature	-40		125	°C	
Operating Frequency	50kHz		2MHz		
Turns Ratio (±2%)		1:1:1			(1 - 6):(2 - 5):(3 - 4)
Inductance (Ls)	264			uH	@100kHz, 0.1Vrms, 0Adc, (1-6)
Leakage Inductance			0.30	uH	@100 KHz, 0.1Vrms, (1-6), short (2-5), (3-4)
Capacitance			95	pF	@100 KHz, 0.1Vrms Pri to Sec
DCR			1.5	Ω	(1-6)
			1.5	Ω	(2-5)
			1.5	Ω	(3-4)
SRF	2.5			MHz	
Volt-time product		24.5		V-usec	
Hipot	500VDC, 1.0mA, 1Sec				Pri to Sec

## OUTLINE DIMENSIONS

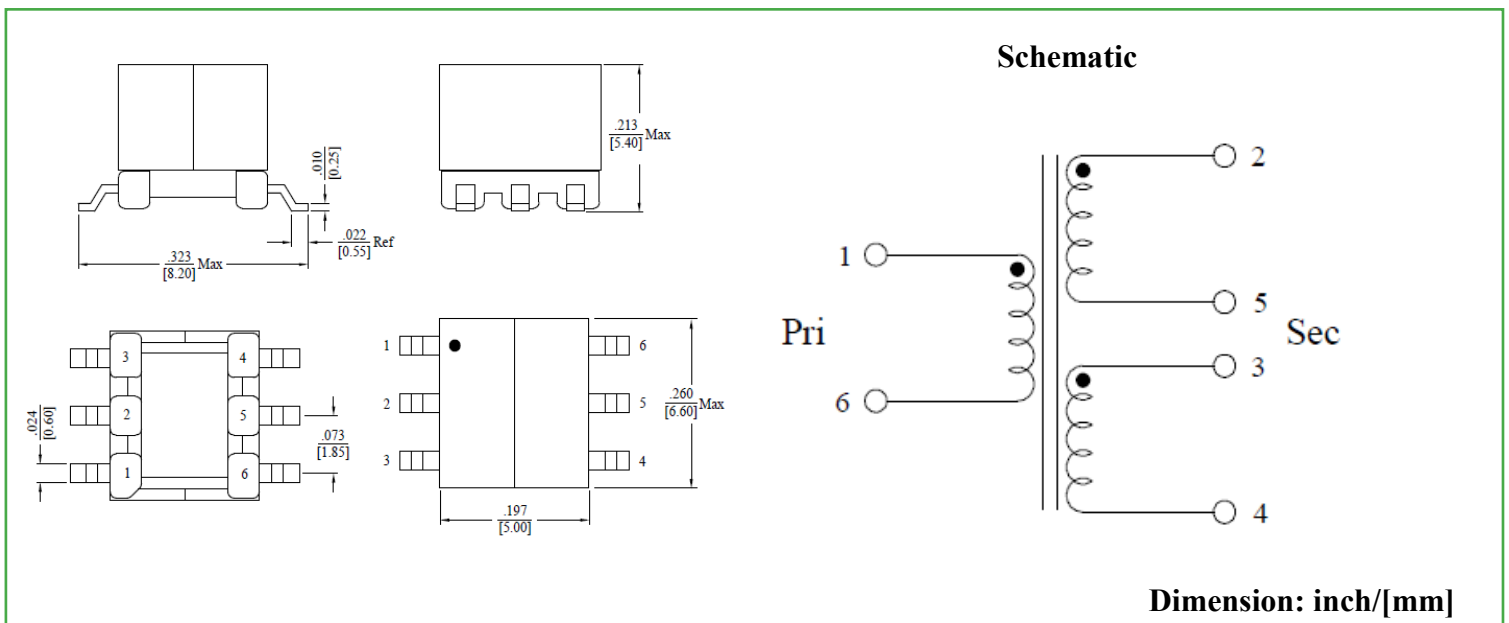

Dimension: inch/[mm]

**GOLDSTONE**  
MAGNETICS

SHAANXI GOLD-STONE ELECTRONICS CO.,LTD

Web: www.gsmagnetics.com Tel:029-85401274 Fax:029-85401274 E-mail:sales@gsmagnetics.com

# SMT Gate Drive Transformer

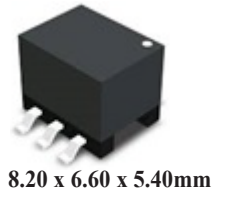

AITC-449



RoHS/RoHS II compliant

8.20 x 6.60 x 5.40mm

## TAPE & REEL:

### Packing

T: Tape and Reel (1kpcs/reel)

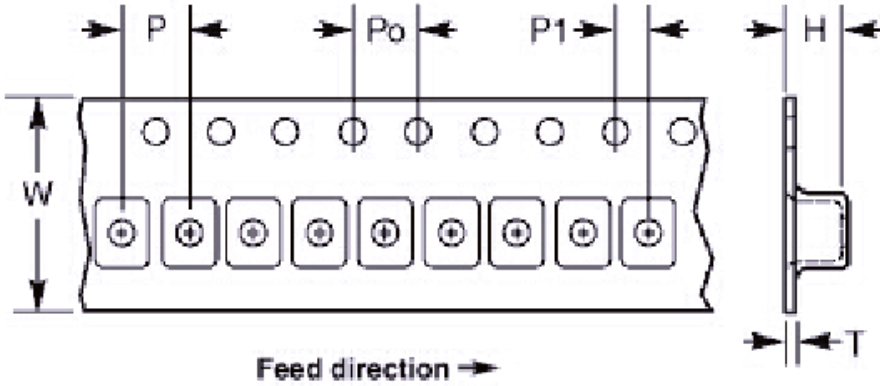

### Orientation

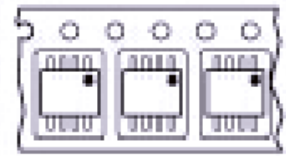

W	P	P0	P1	H	T
16.00	12.00	4.00	2.00	5.54	0.36

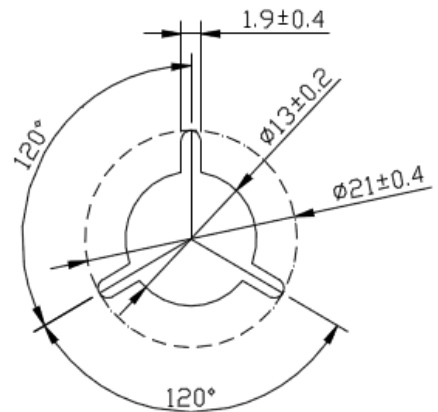
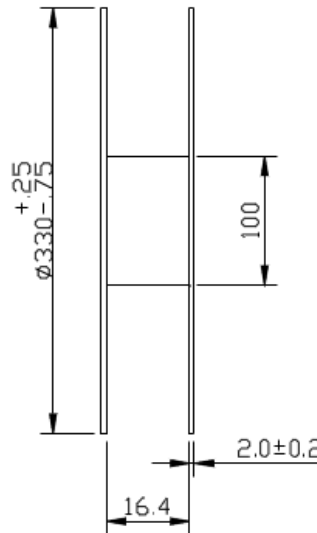
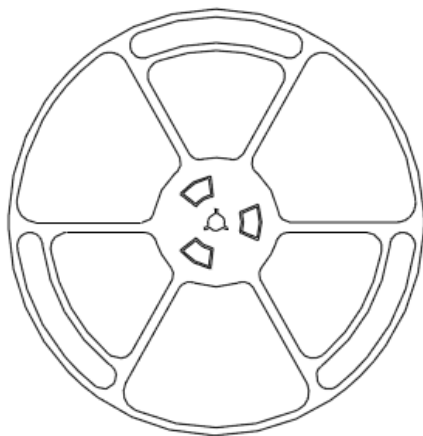

Dimension: mm

**GOLDSTONE**  
MAGNETICS

SHAANXI GOLD-STONE ELECTRONICS CO.,LTD

Web: [www.gsmagnetics.com](http://www.gsmagnetics.com) Tel: 029-85401274 Fax: 029-85401274 E-mail: [sales@gsmagnetics.com](mailto:sales@gsmagnetics.com)