

THRU-HOLE DRUM CORE POWER INDUCTORS

AIRD-01

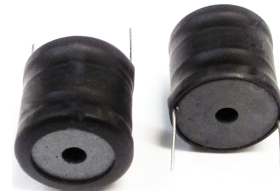

RoHS
Compliant



21.0 x ϕ 16.5 mm

FEATURES:

- Ferrite core with UL tube
- Wire wound construction
- High current, low DCR

APPLICATIONS:

- Electronic Appliance
- Power Supplies
- TRIAC/SCR Control Circuits

STANDARD SPECIFICATIONS

Operating Temperature: -25°C ~ +85°C

Storage Temperature: -25°C ~ +125°C

Part Number	Inductance	Tolerance	DCR (Max)	Saturation Current (Max)	Temperature Rise Current (Max)
Units	μ H	%	Ω	A	A
Symbol	L	K, M	DCR	Isat	Irms
AIRD-01-1R0	1.0	K, M	0.003	87.0	9.0
AIRD-01-1R2	1.2	K, M	0.003	68.0	9.0
AIRD-01-1R5	1.5	K, M	0.004	56.0	9.0
AIRD-01-1R8	1.8	K, M	0.004	56.0	9.0
AIRD-01-2R2	2.2	K, M	0.005	47.0	9.0
AIRD-01-2R7	2.7	K, M	0.005	47.0	9.0
AIRD-01-3R3	3.3	K, M	0.005	40.0	9.0
AIRD-01-3R9	3.9	K, M	0.006	36.0	9.0
AIRD-01-4R7	4.7	K, M	0.007	32.0	9.0
AIRD-01-5R6	5.6	K, M	0.007	29.0	9.0
AIRD-01-6R8	6.8	K, M	0.008	26.0	9.0
AIRD-01-8R2	8.2	K, M	0.009	24.5	9.0
AIRD-01-100	10	K	0.010	21.2	9.0
AIRD-01-120	12	K	0.011	19.0	9.0
AIRD-01-150	15	K	0.015	17.5	7.2
AIRD-01-180	18	K	0.016	16.5	7.2
AIRD-01-220	22	K	0.025	15.8	5.5
AIRD-01-270	27	K	0.030	14.4	4.5
AIRD-01-330	33	K	0.040	13.2	4.0
AIRD-01-390	39	K	0.046	11.8	4.0
AIRD-01-420	42	K	0.050	11.3	3.8
AIRD-01-470	47	K	0.062	11.0	2.8
AIRD-01-560	56	K	0.069	10.0	2.8
AIRD-01-680	68	K	0.077	8.9	2.8
AIRD-01-820	82	K	0.083	8.2	2.8
AIRD-01-101	100	K	0.095	7.5	2.8
AIRD-01-121	120	K	0.127	5.8	2.0
AIRD-01-151	150	K	0.181	5.6	1.6
AIRD-01-181	180	K	0.217	5.1	1.6
AIRD-01-221	220	K	0.240	4.3	1.6
AIRD-01-271	270	K	0.300	4.1	1.6
AIRD-01-331	330	K	0.336	3.8	1.3
AIRD-01-391	390	K	0.460	3.3	1.0
AIRD-01-471	470	K	0.636	3.2	0.8
AIRD-01-561	560	K	0.696	2.9	0.8
AIRD-01-681	680	K	0.700	2.9	0.8

Test Conditions and equipments

Test frequency: 1KHz 0.1VRMS

DCR: QuadTech Milliohm meter

Isat: 10% inductance drops from initial value

Irms: Δ T of 30°C temperature rise max

GOLDSTONE
MAGNETICS

SHAANXI GOLD-STONE ELECTRONICS CO.,LTD

Web: www.gsmagnetics.com Tel: 029-85401274 Fax: 029-85401274 E-mail: sales@gsmagnetics.com

THRU-HOLE DRUM CORE POWER INDUCTORS

AIRD-01



RoHS
Compliant

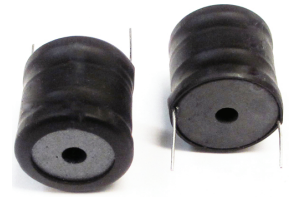

21.0 x ϕ 16.5 mm

PART NUMBER IDENTIFICATION

AIRD-01-

Inductance Code

Please refer to the
Electrical Spec Table

Tolerance

M: $\pm 20\%^*$

K: $\pm 10\%^*$

*M for L = 1.0 ~ 8.2 μ H
K for L = 10.0 ~ 680 μ H

OUTLINE DRAWING:

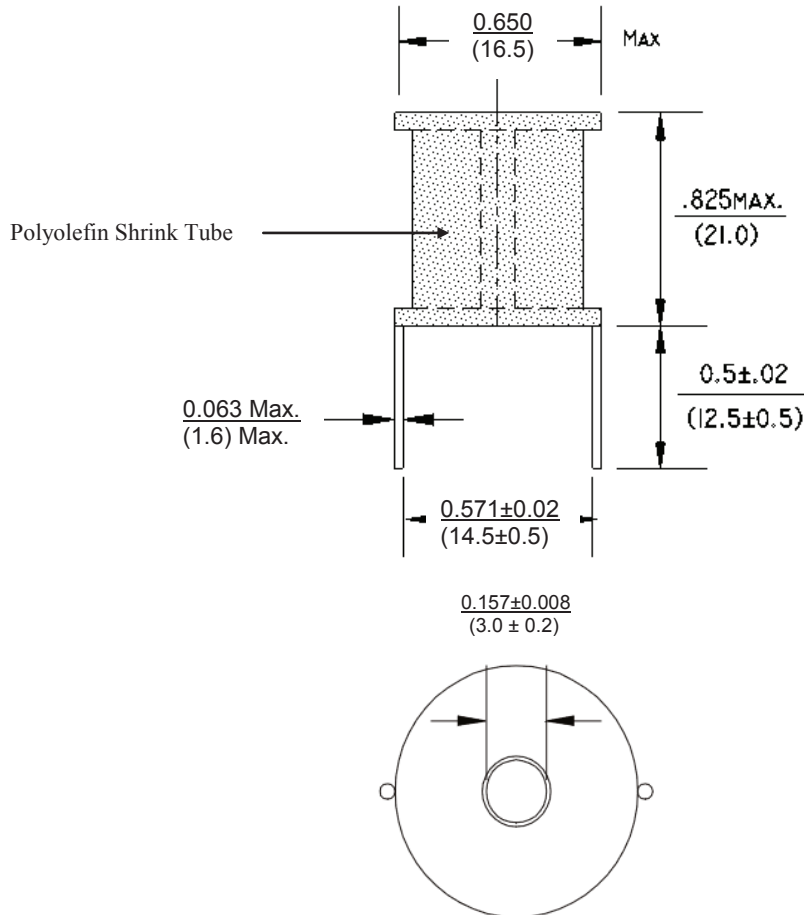

Dimension: inch (mm)

GOLDSTONE
MAGNETICS

SHAANXI GOLD-STONE ELECTRONICS CO., LTD

Web: www.gsmagnetics.com Tel: 029-85401274 Fax: 029-85401274 E-mail: sales@gsmagnetics.com